

Download Clamp shown with Banding Adapter

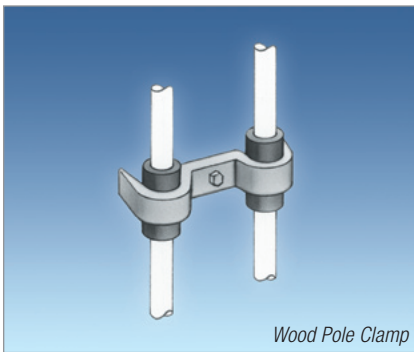

Wood Pole Clamp

### Features

- Slip strength: >100 lbs.
- Lattice adapters provided with break-away bolts for precise torque during installation
- Steel tower guide clamps available with adapters to eliminate the need for drilling
- Banding adapters available

## Download & Wood Pole Clamps

The AFL Download Clamps are used to guide Optical Ground Wire from the top of the structure to the splice box. Our clamps install easily and provide proper spacing and hold strength without damage to the cable. From poles to towers, we offer a full line of OPT-GW Download Clamps to meet the needs of any application.

### Ordering Information – Download Clamp & Adapter

(Note: for metric hardware, add suffix "M" to part number)

OPT-GW DIAMETER (INCHES)	BUSHING COLOR	PART NUMBER
0.400 - 0.500	red	ODC400/500
0.501 - 0.600	green	ODC501/600
0.601 - 0.700	yellow	ODC601/700
0.701 - 0.800	blue	ODC701/800
0.801 - 0.900	white	ODC801/900
0.901 - 1.000	black	ODC901/1000

ADAPTER FOR DOWNLOAD CLAMP	SUFFIX
Banding Adapter	A
Lattice Adapter (up to 0.72" tower leg thickness)	B
Lattice Adapter (up to 1.25" tower leg thickness)	C

Ordering Example:

For AC-64/528 AlumaCore OPT-GW the part number is ODC501/600A

### Ordering Information – Wood Pole Clamp

(Note: not available with metric hardware)

OPT-GW DIAMETER (INCHES)	PART NUMBER
0.469 - 0.561	OGW469/561
0.562 - 0.655	OGW562/655
0.656 - 0.750	OGW656/750

Ordering Example:

For AC-64/528 AlumaCore OPT-GW the part number is OGW469/561